

QY110KH 汽车起重机 / Truck Crane

技术规格书

Technical specifications

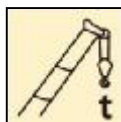

110 t



72 m



97 m



2021年5月 第2版
2nd edition, May 2021

目录 Contents

目录 Contents	
尺寸参数 Dimensions	4
技术规格 Technical specifications	5-8
车型与选装件 Version and optional parts	9
重量 Weight	10
作业速度 Working speeds	11
平衡重 Counterweight	12
运输部件尺寸 Dimension and weight of parts transported	13
臂架组合方案 Boom / Jib combinations	14-15
主臂 Boom	16-18
副臂 Jib	19-22
符号标识 Description of symbols	23
主要技术参数表 Table of main technical parameters	24-25
注意事项 Notes	26

尺寸参数 Dimensions

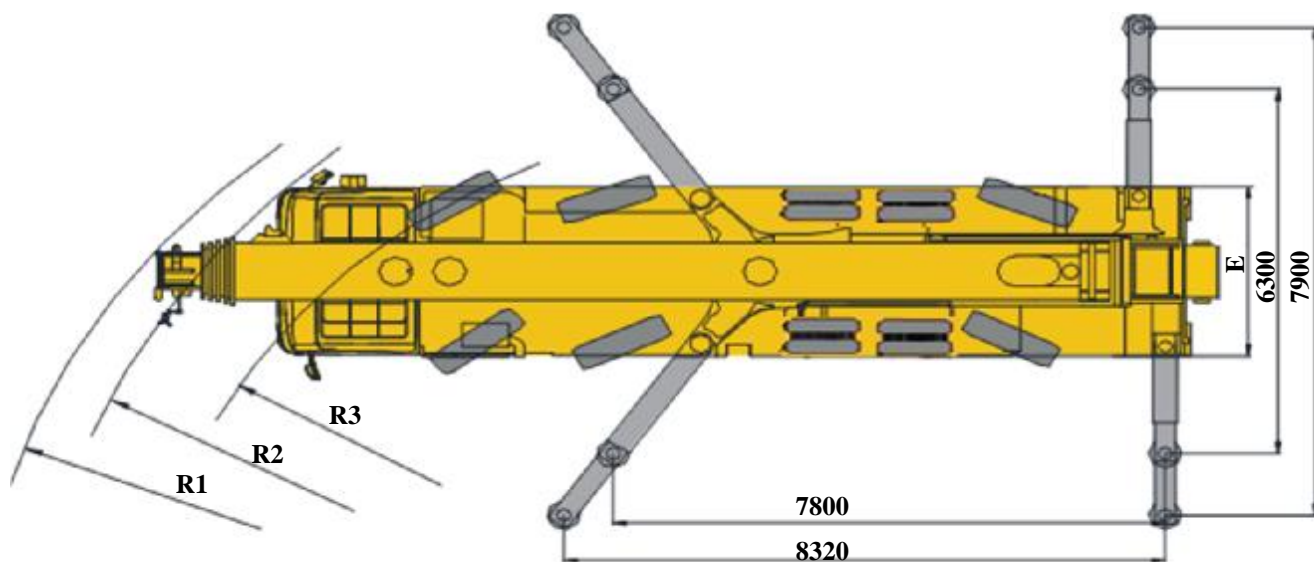
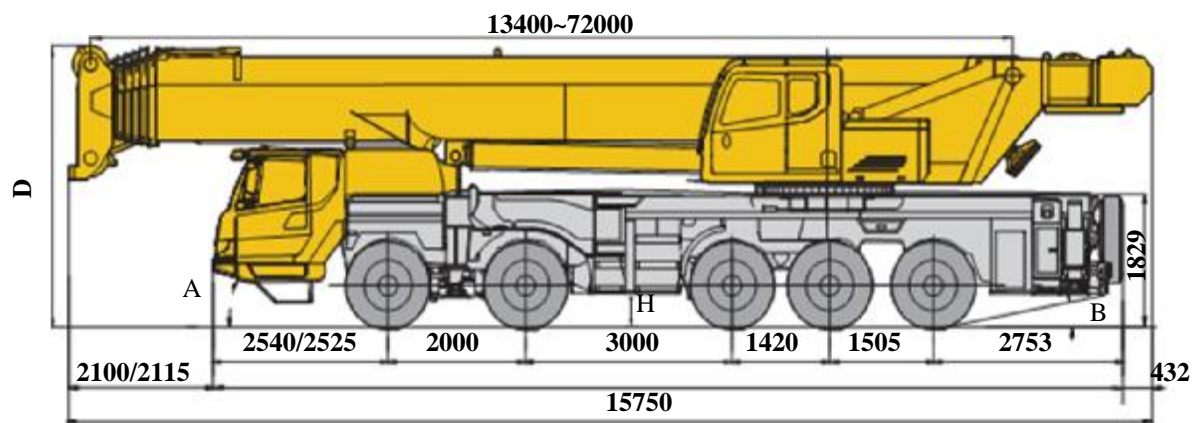

	A	B	D	E	R1	R2	R3	H
325/95R24或12.00R24	18°	11°	3900	3000	14.4	13	11.5	270

技术规格

Technical specifications

	底盘
车架	徐工设计、制造，全覆盖式走台板，防扭转箱型结构，高强度钢材制造。
支腿	4支腿，前双节摆腿后水平支腿结构，水平伸缩和垂直伸缩由液压控制，底盘两侧装有电控操纵控制台，控制台板装有水平仪、照明灯和调速按钮，支腿油缸均设有单向阀，且垂直支腿带有双向液压锁。 支脚盘尺寸：473mm×608mm 最大起重量时支腿反力：811kN
发动机	WP10.5H430E50，直列六缸水冷电控柴油发动机，潍柴制造 额定功率316kW/1900rpm 大扭矩2000Nm/1000-1400rpm 最大基准扭矩：2187 N.m 国五排放标准 燃油箱容积：500L 尿素箱容积：35L
变速箱	机械式变速箱，10个前进档，2个倒档，带同步器。
车桥	高强度车桥，1,2,5桥转向，3,4,5桥驱动。
悬挂	前悬架采用板簧悬架，后悬架采用双纵臂板簧平衡悬架。
轮胎	14个轮胎，1个备胎，1,2,5桥装单胎，3,4桥装双胎，双钱/泰凯英制造。 轮胎规格：325/95R24或12.00R24。

	底盘
制动	行车制动：双回路气压制动，作用于所有车轮。 驻车制动：弹簧储能制动，作用于2,3,4,5轴车轮。 辅助制动：发动机排气制动和缓速制动。
转向	1,2,5桥转向，1、2桥机械转向+液压助力，5桥缸控随动转向，可适应多种工况的要求，实现多种转向模式。
驾驶室	新型复合结构全宽驾驶室，全封闭、装备豪华舒适。性能上：优越的密封性和防腐蚀、防震设计；配置大视野的前挡风安全玻璃、后视镜，电控洗涤器，电子门窗升降器，带有除霜风挡的室内空气加热器，冷暖空调，收放音机、丝网地垫等。主驾采用机械减震座椅，副驾采用简易卧铺。3公斤灭火器标配冷暖空调。
电气系统	直流24伏特，串联12伏特的电池组2个。发电机，28伏特-80安培。

技术规格

Technical specifications



上车

结构	徐工设计、制造，高强度钢材制造。
液压系统	电比例变量泵用于起升、变幅、伸缩；回转采用闭式泵驱动；比例电磁换向控制阀；风冷式液压油散热器； 液压油箱有效容积：592L
操纵方式	电比例操纵，无级调速，由左右2个操纵手柄控制起重机的主要动作。
主起升机构	液压控制调速，由液压马达通过行星齿轮减速器驱动，内置常闭式制动器并带有平衡阀，装有绳槽卷筒。
副起升机构	液压控制调速，由液压马达通过行星齿轮减速器驱动，内置常闭式制动器并带有平衡阀，装有绳槽卷筒。
回转机构	单排四点接触球外齿式回转支承，由液压马达通过行星齿轮减速器驱动，内置常闭式制动器，可连续回转360°，具有动力控制或自由滑转的功能，可无级调速。
变幅机构	单变幅油缸，带有负载补偿功能的变幅平衡阀，变幅下落采用平衡阀外控式重力+动力下降方式。
操纵室	钢制操纵室，无视野死角的前景窗，安全玻璃，推拉式车门，可调式电加热功能座椅，可翻仰20°，装有前窗顶窗遮阳帘、顶窗双层遮阳帘，后窗遮阳帘；雨刮器、顶部防护栏、推拉踏板，配备力矩限制器、人机交互系统控制面板、电控扶手箱、发动机动力加速踏板、发动机起动开关等。标配冷暖空调、2kg灭火器。
安全装置	液压平衡阀；液压溢流阀；液压双向锁；力矩限制器；三圈保护器；起升高度限位器；风速仪；卷扬监视装置
组合配重	总重36t。





上车

起重钩	60t钩 7t钩
主臂	7节，“U”形截面的筒形焊接结构，单板式臂头、紧凑式臂尾。单缸插销伸缩机构 主臂长度：13.4m~72m。
副臂	由连接架、旋转架和两节桁架结构折叠式副臂组成，具有0°、15°、30°三种安装角，收存于主臂旁。 副臂长度：10.5m、17.5m
臂端单滑轮	单滑轮，安装在主臂顶端，用于单股钢丝绳起重作业，起重性能与主臂相同，但最大起重量不超过7t。
主臂加长节	两节桁架式焊接结构，与主臂臂头固定安装 主臂加长节长度：7m，2节
独立臂头	桁架式焊接结构，与主臂臂头固定安装。 独立臂头长度：2.9m

技术规格

Technical specifications

 Chassis	
Frame	Designed and manufactured by XCMG, it is made of high strength steel with fully covered walking surface and anti-torsion box-typed structure.
Outrigger	Four outriggers; front two-stage outrigger beams are swung, and rear outrigger beams are extended. Outrigger beams and jacks are hydraulically controlled. There is an outrigger control station located at each side of the chassis, and there is a level gauge, an illuminator and speed buttons on each control station. There is a check valve fitted in each outrigger cylinder, and a double-way hydraulic valve fitted in each jack cylinder. Float dimension: 473 mm×608 mm Reaction force of outrigger at max. lifting load: 811 kN
Engine	WP10.5H430E50, in-line, 6-cylinder, water cooled, electric control diesel engine, made by WEICHAI, with rated power of 316 kW/1900 rpm and max. torque of 2000 Nm/1000-1400 rpm, Max.reference torque/rpm : 2187 N.m compliant with China V emission standard. Fuel tank capacity: 500 L. AdBlue tank volume : 35L.
Transmission	Mechanical transmission, 10 forward speeds and 2 reverse speeds with a synchronizer.
Axles	High strength axles, axles 1,2,5 are for steering, axles 3,4,5 are for driving.

 Chassis	
Suspension	Leaf springs are adopted for front suspensions; double trailing arm type suspensions are adopted for rear suspensions.
Tires	14 tires and 1 spare tire, axle 1,2,5 are equipped with single tire, axle 3,4 are equipped with double-tire, manufactured by Double Coin/Techking. Tire specifications:325/95R24 or12.00R24 .
Brakes	Service brake: double-circuit air pressure brake acting on all wheels. Parking brake: spring-loaded brake, acting on wheels of axles 2,3,4,5. Auxiliary brake: engine exhaust brake, engine retarder brake
Steering	Axles 1 and 2 are mechanically steered + hydraulic power assistance; axle 5 is steered through cylinder control. Various steering modes can accommodate to different working conditions..
Driver's cab	New enclosed cab, luxury and comfort. It is designed to be leak-proof, anti-corrosive and shock-proof. It is equipped with a windshield offering outstanding visibility, electrical adjustable rear mirrors, electric control washer, electronic lifters of doors and windows, air heater with defrosting function, heater & air conditioner, radio player and new material mat, etc. A mechanical shock absorber seat is supplied for driver and a simple sleeper for co-driver. A fire extinguisher of 3 kg is available. Heater and air conditioner are standard.
Electrical system	24V DC, two sets of 12 V battery in series. Generator: 28 V-80 A

技术规格

Technical specifications



Superstructure

Frame	Designed and manufactured by XCMG, made of high strength steel.
Hydraulic system	Electric proportional variable pump is used for lifting, elevating and telescoping operations. A closed pump is used to drive slewing operation. The proportional solenoid directional control valve; air-cooled hydraulic oil radiator. Effective volume of hydraulic oil tank: 592 L
Control system	The electric proportional control system is equipped with two levers at left and right sides controlling the main movements of the crane, and stepless slewing speed regulation is available.
Main winch system	Hydraulic control is used for speed regulation. The system is driven by a hydraulic motor through a planetary gear reducer, with a normally closed brake, a balanced valve and a grooved drum equipped.
Auxiliary winch system	Hydraulic control is used for speed regulation. The system is driven by a hydraulic motor through a planetary gear reducer, with a normally closed brake, a balanced valve and a grooved drum equipped.
Slewing system	A single-row, four-point contact-ball external slewing bearing; the system is driven by a hydraulic motor through a planetary gear reducer with constant-closed brake equipped, and may continuously slew 360°. Power control and free slewing function as well as stepless speed regulation are available.
Luffing system	Single luffing cylinder and the luffing counterbalance valve with the load compensation function. Balance valve-controlled boom gravity combined with power for lowering boom is used for boom luffing down.



Superstructure

Operator's cab	Steel cab with a full-view windshield, safety glass, sliding door, adjustable seat with electric heating function; it can tilt backward about 20°; double-layer sun shield is adopted for roof window; sun shield is also equipped at the windshield and rear window; wipers, roof guardrails, pull-out step, LMI, human-machine interactive control panel, electric controlled armrest, engine accelerator pedal, engine start switch, etc. are also available. Heater, air conditioner and fire extinguisher of 2 kg are standard.
Safety devices	Hydraulic counterbalance valve; hydraulic relief valve; hydraulic double-way valve; LMI; lowering limiter; anti-two block; anemometer; winch monitoring device
Combined counterweight	Total weight is 36 t.
Hook block	60 t 7 t
Boom	7-section boom with U cross-section, welding structure, with single-plate boom head and compact boom tail. Single-cylinder pinning telescoping system, Boom length: 13.4 m~72 m.
Jib	The jib consists of a connecting bracket, a rotating bracket and two lattice sections. Three offset angles of 0°, 15° and 30° are available. It is stowed along the side of the boom. Jib length: 10.5 m, 17.5 m
Single top	Installed at the boom top, used for single line operation. Its lifting performance is the same as that for boom, but the max. lifting load could not exceed 7 t.
Boom extension	Two-section lattice jib, welded structure, attached to boom head. Length of boom extension: 7 m
Independent jib head	Lattice welded structure, attached to boom head. Length of independent jib head is 2.9 m

车型与选装件

Version and optional parts

车型 Version	功能描述/Function description	选择 Selection
标准型 Standard	七节主臂72m，固定副臂17.5m，2节7m加长节，独立臂头2.9m 7-section boom of 72 m, fixed jib of 17.5 m, two-section boom extension of 7 m, independent jib head of 2.9 m	

注释：该产品仅标准型一种车型。

Note: only the standard version is available.

	可选装件 Optional parts	选择 Selection
	95吨钩	
	95 t	
吊钩 Hook block	80吨钩	
	80 t	
	50吨钩	
	50 t	

重量

Weight



Axle	1	2	3	4	5	总重量 Total weight
t	9.3	9.3	13	13	10	54.6 ¹⁾
t	10.2	10.2	22	22	17	81.4 ²⁾

1) 上车不带起重吊钩、副臂、臂端单滑轮，带2t平衡重；转向驱动形式：10×6×6；轮胎规格：325/95R24或12.00R24；

Superstructure: without the hook block, jib, single top; with counterweight of 2 t.

Steer & Driving type: 10×6×6; Tire specification: 325/95R24 or 12.00R24.

2) 短途转场状态，最高车速20km/h，带50t钩、副臂、副卷，27t平衡重，备胎及备胎支架；转向驱动形式：10×6×6；轮胎规格：325/95R24或12.00R24；

Short-distance job site transfer: max. travel speed is 20 km/h, carry the 50 t hook block, jib, auxiliary winch, counterweight of 27 t, spare tire and its bracket on board.

Steer & Driving type: 10×6×6; Tire specification: 325/95R24 or 12.00R24.



吊钩 Hook block	倍率 Parts of line	吊钩重量 Weight kg	吊钩尺寸 Dimensions mm	备注 Remarks
95 t	12	1010	1841×858×610	双钩 Double hook , 选配 Optional
80 t	12	700	1735×600×529	单钩 Single hook , 选配 Optional
50 t	7	515	1586×560×380	单钩 Single hook , 选配 Optional
7 t	1	256	731×426×426	单钩 Single hook , 标配 Standard
60 t	7	580	1500×610×590	双钩 Double hook , 标配 Standard

作业速度 Working speeds



325/95R24或12.00R24



1 ~ 80



45%



作业机构 Operation mechanism	作业速度 Working speed	最大单绳拉力 Max. single line pull	钢丝绳直径/长度 Rope diameter/ length
	0-130 m/min, 单绳, 第四层 m/min, single line, 4th layer	82.3 kN	20 mm/290 m
	0-90 m/min, 单绳, 第四层 m/min, single line, 4th layer	68.6 kN	20 mm/205 m
	0-1.8 r/min		
	从-1°抬起至81°约65s Approx. 65 s for boom luffing from -1° to 81°		
	从13.4m伸出至72m约615s Approx. 615 s for boom extending from 13.4 m to 72 m		

平衡重 Counterweight

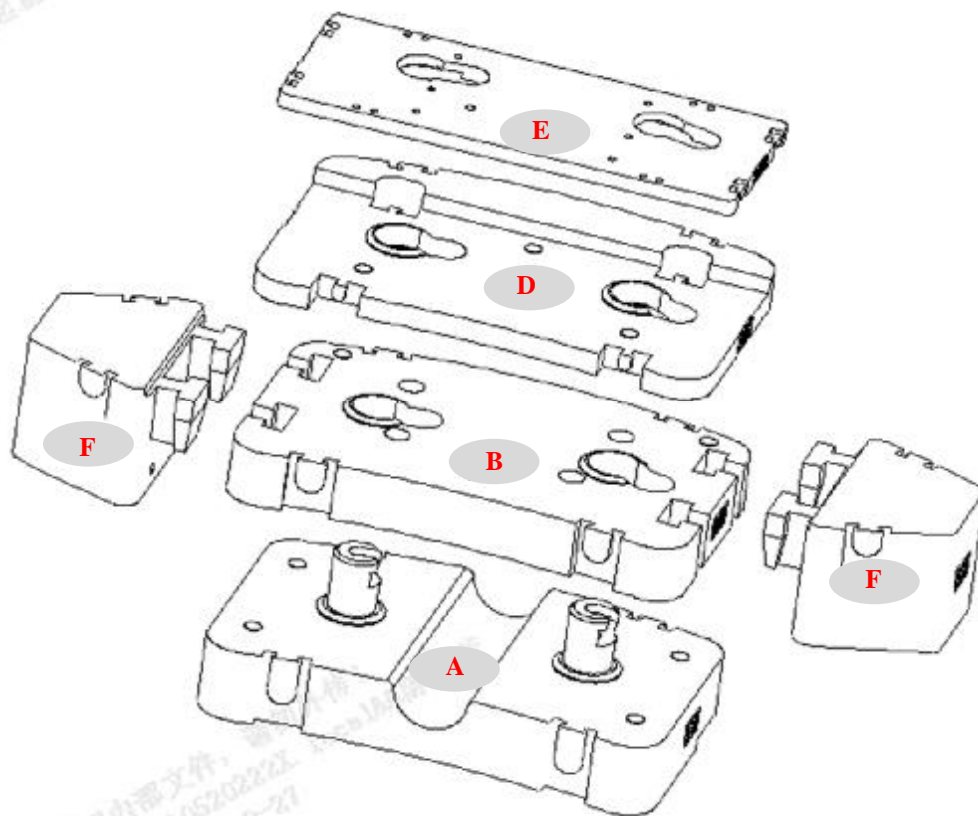

平衡重 Counterweight	A	B	D	E	F
尺寸 (长×宽×高) mm	2740×1720 ×815	2740×1720 ×369	2740×1720 ×232	2740×1132 ×93	1065×1238 ×763
Dimensions (L×W×H) mm					
重量 t Weight t	12	9	4	2	4.5

工况模式 Working condition	36t	27t	23t	18t	14t	6t	2
组合形式 Combinations	A+B+D+E +2F	A+B+D+E	A+B+E	A+D+E	A+E	D+E	E

运输部件尺寸

Dimension and weight of parts transported

副臂及支架 1300kg
Jib and the bracket 1300 kg

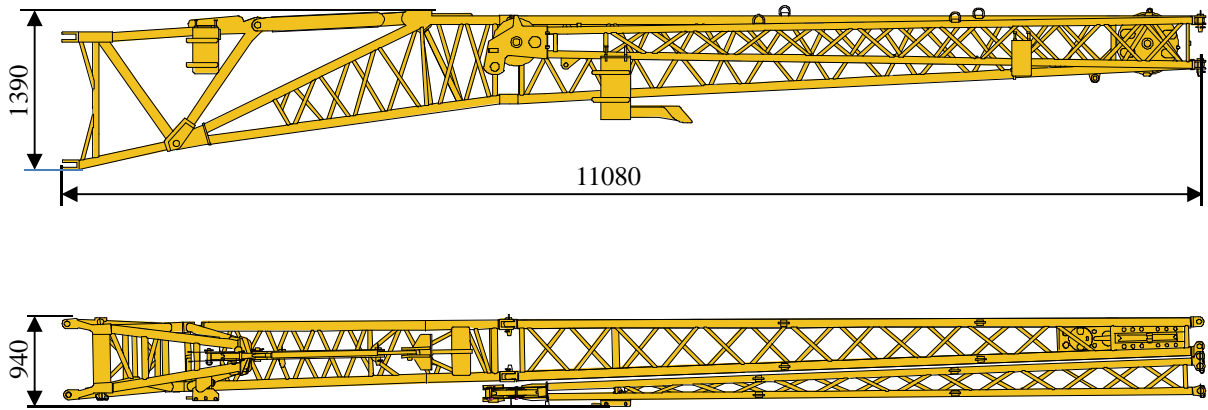

主臂加长节 466kg
Boom extension 466 kg

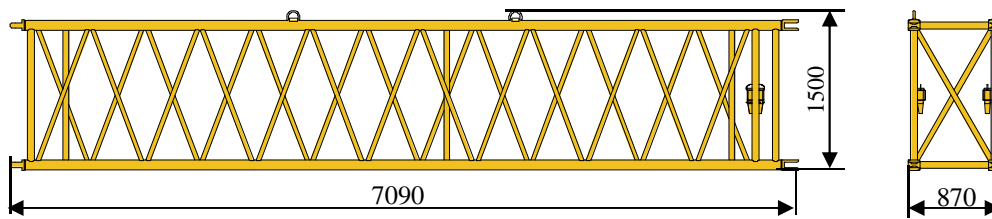

独立臂头 440kg
Independent jib head 440 kg

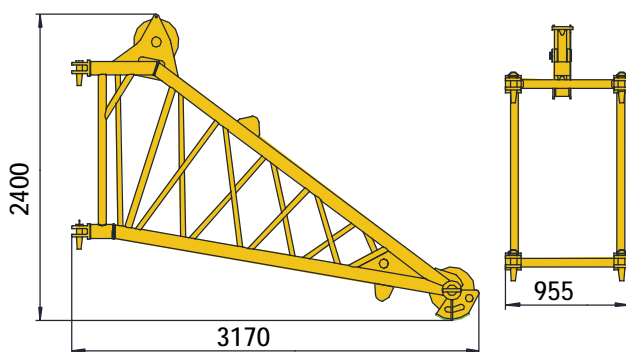

臂端单滑轮 95kg
Single top 95 kg

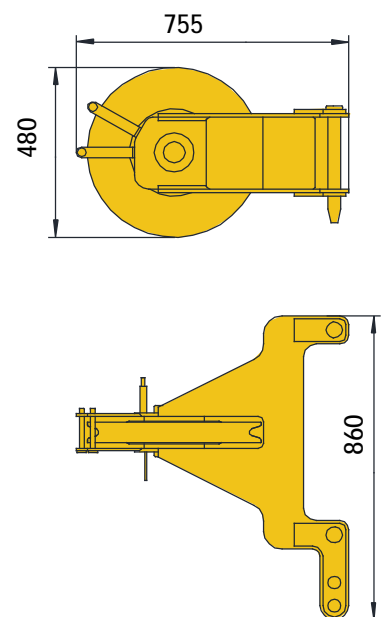

臂架组合方案

Boom / Jib combinations

副臂 - 10.5m
Jib - 10.5 m



副臂 - 17.5m
Jib - 17.5 m

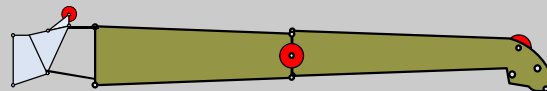

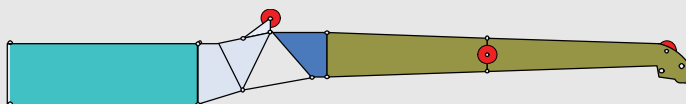

主臂加长节 - 24.5m
Boom extension -
24.5 m

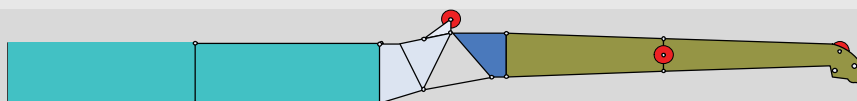

主臂加长节 - 31.5m
Boom extension -
31.5 m

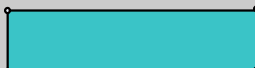

部件 Parts	结构形式 Structure	尺寸 (长×宽×高) mm Dimensions (L×W×H) mm	重量 kg Weight kg
连接架 Connecting bracket		2035×870×1573	235
主臂加长节 Boom extension		870×1500×7090	466
一节副臂总成 1st jib section assembly		9923×1106×790	578
二节副臂总成 2nd jib section assembly		6908×608×446	265

臂架组合方案

Boom / Jib combinations



主臂
Telescopic boom

T : 13.4~72 m

副臂
Jib

T : 58.3~67.3 m
J : 10.5~17.5 m

主臂加长节
Telescopic boom extension

T : 58.3~67.3 m
I : 14 m
J : 10.5~17.5 m

起升高度曲线图 Lifting height chart

主臂
Boom

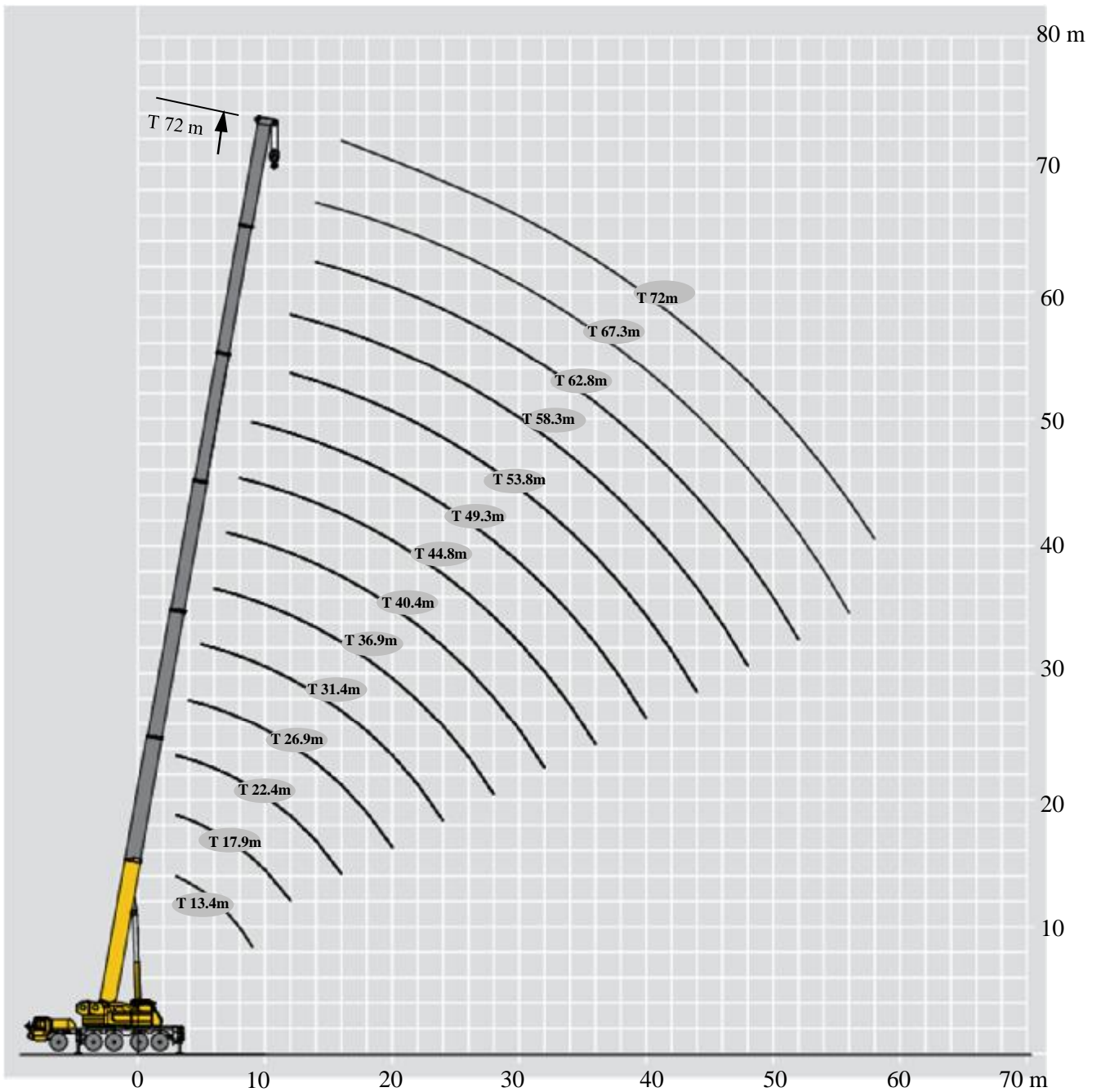

起重性能表

Lifting load tables

T 13.4~44.8 m

	13.4-31.4 m		8.32 m×7.9 m		360°		36 t															
	13.4	17.9	17.9	17.9	22.4	22.4	22.4	22.4	26.9	26.9	26.9	26.9	31.4	31.4								
3	110.0*	58.2	80.0	85.0	41.9	62.1	78.0	80.0							3							
3.5	90.0	55.2	78.0	82.0	38.9	59.2	75.0	78.0							3.5							
4	88.0	52.4	75.0	79.0	36.7	56.8	72.0	75.0	37.5	59.5	68.0	70.0			4							
4.5	80.0	49.8	70.0	77.0	34.8	54.3	69.0	72.0	35.5	57.0	65.0	68.0			4.5							
5	74.0	47.6	65.0	72.0	33.0	51.9	65.0	68.0	33.7	54.8	62.0	66.0	35.4	56.7	5							
6	64.0	43.6	60.0	63.0	29.9	48.2	60.0	63.0	30.6	51.5	60.0	61.0	32.4	53.4	6							
7	54.0	40.4	52.0	54.0	27.5	44.9	53.0	54.0	27.9	47.9	53.0	54.0	29.8	50.3	7							
8	47.0	37.6	45.0	47.0	25.3	42.1	47.0	48.0	25.6	44.2	47.0	48.0	27.6	47.0	8							
9	40.0	35.3	38.0	42.0	23.5	39.5	41.0	42.0	23.8	40.4	40.0	42.0	25.8	41.0	9							
10		33.2	34.0	38.0	21.9	36.6	37.0	38.0	22.1	36.0	36.0	38.0	24.0	35.0	10							
12		29.9	30.0	31.5	19.2	31.5	31.0	30.0	19.4	31.0	31.0	30.0	21.2	30.0	12							
14					17.1	27.0	27.0	26.0	17.2	27.0	27.0	26.0	19.0	26.0	14							
16					15.5	23.0	23.0	22.5	15.5	23.5	23.0	22.0	17.2	23.0	16							
18									14.0	20.9	19.5	18.8	15.6	20.8	18							
20									12.8	17.7	16.8	15.8	14.4	17.7	20							
22													13.3	15.2	22							
24													12.4	13.2	24							
组合 Code	000000	000001	000010	000100	000002	000011	000110	001100	000012	000111	001110	011100	000112	001111	组合 Code							

说明：*为名义载荷，表示起重机能力等级

Note : * means capacity class

	31.4-44.8 m		8.32 m×7.9 m		360°		36 t															
	31.4	31.4	35.9	35.9	35.9	35.9	40.4	40.4	40.4	40.4	44.8	44.8	44.8	44.8								
5	62.0	60.0													5							
6	58.0	57.0	26.6	33.6	48.0	50.0									6							
7	53.0	52.0	24.6	31.2	48.0	50.0	25.1	32.0	48.0	34.9					7							
8	48.0	47.0	22.8	29.1	45.0	47.0	23.4	30.2	46.0	32.4	19.9	23.8	31.9	33.8	8							
9	42.5	43.0	21.2	27.2	41.0	43.0	22.1	28.4	42.0	30.1	18.9	22.5	30.0	31.9	9							
10	36.0	38.0	19.9	25.7	37.0	38.0	20.7	26.8	38.0	28.0	17.8	21.3	28.2	30.0	10							
12	30.0	31.0	17.6	22.8	32.0	32.0	18.6	24.0	32.0	24.6	15.9	19.2	25.2	26.6	12							
14	26.0	27.0	15.6	20.5	27.0	27.0	16.5	21.8	27.0	21.6	14.3	17.4	22.6	23.9	14							
16	23.7	22.3	14.1	18.7	23.0	22.5	15.0	19.9	23.0	19.2	13.0	15.8	20.3	21.3	16							
18	19.6	18.3	12.8	17.1	20.4	19.0	13.6	18.3	19.8	17.2	11.9	14.4	18.5	19.2	18							
20	16.5	15.2	11.6	15.7	17.3	16.0	12.5	16.9	16.7	15.5	10.8	13.4	16.5	16.1	20							
22	14.1	12.8	10.6	14.6	14.9	13.5	11.6	15.4	14.3	14.1	10.0	12.3	14.1	13.7	22							
24	12.2	10.9	9.7	13.6	12.9	11.6	10.7	13.4	12.3	12.5	9.2	11.4	12.1	11.8	24							
26			9.0	12.2	11.3	10.0	9.9	11.8	10.7	10.9	8.5	10.7	10.5	10.2	26							
28			8.4	10.8	9.9	8.7	9.3	10.5	9.4	9.5	7.8	10.0	9.2	8.8	28							
30							8.6	9.3	8.2	8.4	7.4	9.4	8.0	7.7	30							
32							8.1	8.3	7.2	7.4	6.9	8.6	7.0	6.7	32							
34											6.5	7.7	6.2	5.8	34							
36											6.1	6.9	5.4	5.0	36							
组合 Code	011110	111100	000122	001112	011111	111110	001122	011112	111111	021111	001222	011122	121111	211111	组合 Code							

起重性能表

T 49.3~72 m

Lifting load tables

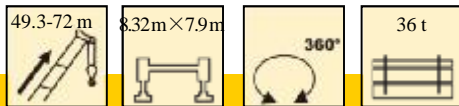

	49.3	49.3	49.3	49.3	53.8	53.8	53.8	53.8	58.3	58.3	58.3	62.8	62.8	67.3	72	
9	18.8	22.3	25.2	27.0												9
10	17.9	21.3	24.0	26.0												10
12	16.1	19.4	21.6	23.4	15.2	15.9	18.6	19.7	14.1	14.3	15.0					12
14	14.6	17.9	19.7	21.0	14.2	14.7	16.9	18.5	13.8	14.3	15.0	11.4	11.8	9.3		14
16	13.4	16.4	17.8	18.9	13.1	13.5	15.5	16.9	13.0	13.7	15.0	11.4	11.8	9.3	6.7	16
18	12.3	15.0	16.1	17.2	12.1	12.6	14.2	15.3	12.2	12.7	13.9	11.4	11.8	9.3	6.7	18
20	11.4	13.9	14.7	15.6	11.0	11.6	13.0	14.0	11.4	11.7	12.7	10.7	11.3	9.3	6.7	20
22	10.5	13.0	13.5	13.6	10.1	10.9	12.0	12.8	10.8	10.9	11.5	10.0	10.4	9.3	6.7	22
24	9.8	12.1	12.2	11.6	9.2	10.1	11.0	11.7	10.0	10.0	10.3	9.1	9.5	8.8	6.7	24
26	9.1	11.3	10.6	10.0	8.4	9.5	10.2	10.2	9.4	9.1	9.5	8.2	8.5	7.8	6.7	26
28	8.4	10.2	9.2	8.7	7.7	8.9	9.4	8.8	8.6	8.4	8.7	7.5	7.7	7.2	6.5	28
30	7.8	9.0	8.1	7.6	7.1	8.3	8.3	7.7	7.9	7.7	7.8	6.9	7.0	6.6	5.8	30
32	7.4	8.0	7.1	6.6	6.7	7.8	7.3	6.7	7.3	7.1	6.9	6.5	6.5	6.0	5.5	32
34	7.0	7.2	6.2	5.7	6.2	7.3	6.4	5.8	6.8	6.6	6.1	6.0	6.0	5.6	5.1	34
36	6.6	6.4	5.4	4.9	5.7	6.5	5.6	5.1	6.4	5.9	5.3	5.6	5.5	5.2	4.5	36
38	6.2	5.7	4.8	4.3	5.3	5.9	5.0	4.4	5.8	5.3	4.6	5.2	4.9	4.8	4.2	38
40	5.7	5.1	4.2	3.7	5.0	5.2	4.4	3.8	5.2	4.7	4.0	4.8	4.3	4.4	3.9	40
42					4.8	4.7	3.8	3.3	4.7	4.1	3.5	4.5	3.7	4.1	3.6	42
44					4.4	4.2	3.4	2.8	4.2	3.6	3.0	4.0	3.3	3.6	3.3	44
46									3.7	3.2	2.6	3.5	2.8	3.2	3.0	46
48									3.3	2.8	2.2	3.1	2.4	2.8	2.8	48
50												2.8	2.1	2.4	2.4	50
52												2.5	1.7	2.1	2.1	52
54														1.8	1.8	54
56														1.5	1.5	56
58															1.3	58
组合 Code	011222	111122	122111	221111	012222	111222	122211	222111	112222	122221	222211	122222	222221	222222	333333	组合 Code

起升高度曲线图
Lifting height chart

副臂
Jib

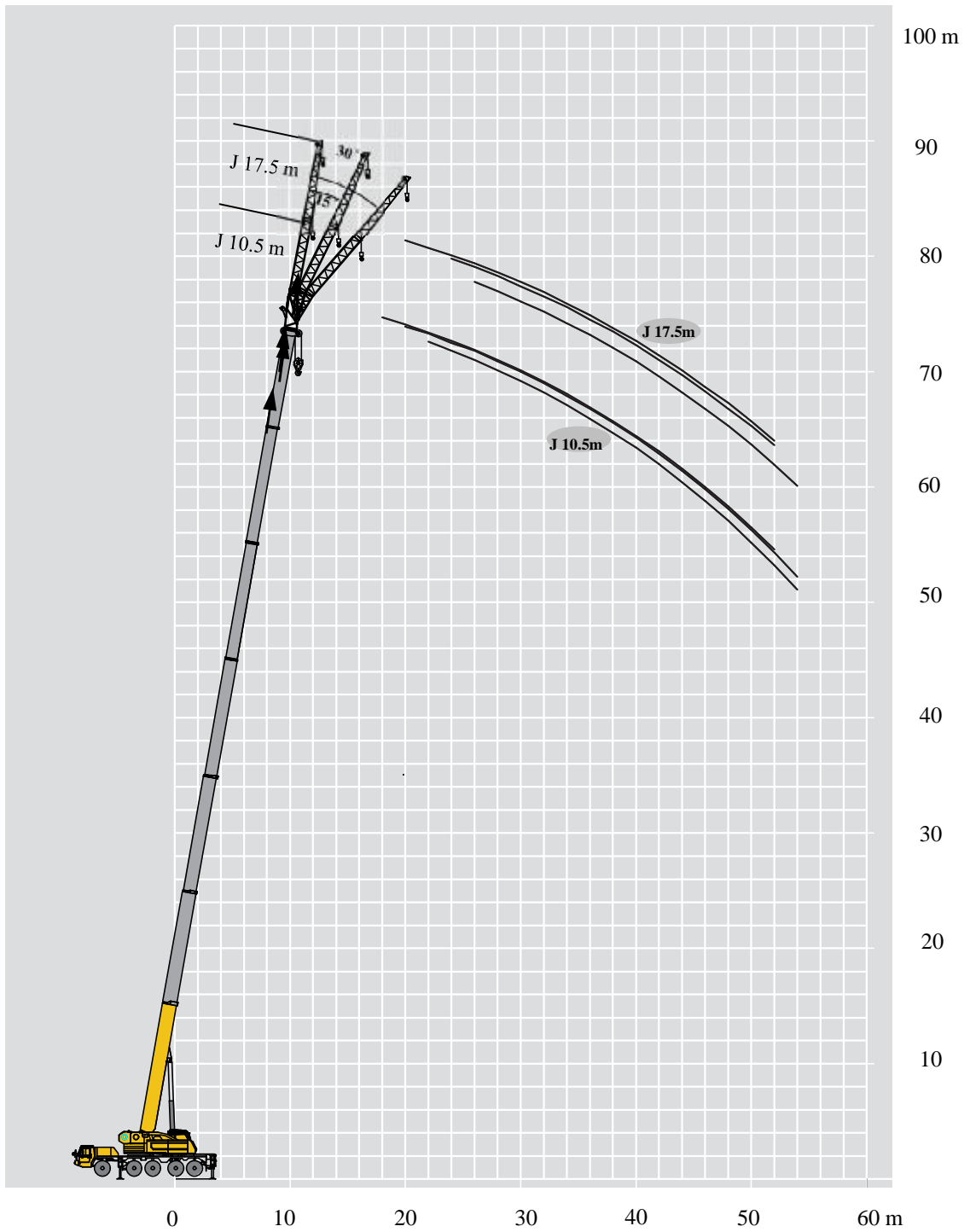

起重性能表

Lifting load tables

J 10.5 m/17.5 m

		58.3-67.3 m			10.5 m			8.32m×7.9m			360°			36 t		
		58.3 m			62.8 m			67.3 m								
		0°	15°	30°	0°	15°	30°	0°	15°	30°						
14	7											14				
16	7	6.5			6.3							16				
18	7	6.3	4.9		6.3	5.9		5				18				
20	6.9	6.2	4.8		6.3	5.7	4.6	5	4.9			20				
22	6.6	6	4.7		6.1	5.6	4.6	5	4.9	4.3		22				
24	6.4	5.7	4.7		5.9	5.5	4.4	5	4.9	4.3		24				
26	6.2	5.6	4.5		5.7	5.3	4.4	5	4.9	4.1		26				
28	5.8	5.4	4.4		5.2	5	4.3	4.7	4.6	4.1		28				
30	5.3	5.2	4.3		4.7	4.5	4.2	4.1	4.1	4.1		30				
32	4.8	4.7	4.2		4.2	4.2	4.1	3.7	3.8	3.7		32				
34	4.2	4.1	4		3.7	3.7	3.7	3.5	3.4	3.5		34				
36	3.7	3.8	3.9		3.4	3.4	3.3	3	3.2	3.1		36				
38	3.4	3.3	3.4		2.9	3	3	2.7	2.8	2.8		38				
40	3.1	3	3.1		2.6	2.7	2.7	2.4	2.5	2.5		40				
42	2.6	2.8	2.8		2.3	2.5	2.4	2.2	2.2	2.3		42				
44	2.3	2.5	2.6		2	2.2	2.2	1.9	2	2		44				
46	2.1	2.2	2.3		1.9	1.9	1.9	1.7	1.8	1.8		46				
48	1.8	1.7	2		1.6	1.6	1.7	1.5	1.6	1.6		48				
50	1.6	1.5	1.8		1.4	1.5	1.5	1.3	1.4	1.4		50				
52	1.4	1.4	1.6		1.2	1.2	1.3	1.1	1.2	1.3		52				
54	1.2	1.2	1.3						1.1	1.1		54				
组合 Code	222211			222221			222222									

		58.3-67.3 m			17.5 m			8.32m×7.9m			360°			36 t		
		58.3 m			62.8 m			67.3 m								
		0°	15°	30°	0°	15°	30°	0°	15°	30°						
16	4.6											16				
18	4.4				4.1							18				
20	4.2	3.5			3.9			3.6				20				
22	4.1	3.4			3.8	3.3		3.6				22				
24	4	3.3	2.3		3.7	3.1		3.5	2.9			24				
26	3.9	3.3	2.3		3.6	3.1	2.3	3.4	2.9	2.1		26				
28	3.7	3.2	2.2		3.5	3.1	2.3	3.3	2.9	2.1		28				
30	3.6	3.1	2.1		3.4	2.9	2.2	3.2	2.8	2.1		30				
32	3.4	3	2.1		3.4	2.9	2.1	3.2	2.8	2.1		32				
34	3.3	3	2		3.3	2.8	2.1	3.1	2.7	2		34				
36	3.3	2.9	2		3.1	2.8	2	2.9	2.7	2		36				
38	3.2	2.9	1.9		2.8	2.7	2	2.6	2.7	2		38				
40	3.1	2.8	1.9		2.6	2.7	1.9	2.4	2.4	1.9		40				
42	2.7	2.7	1.9		2.3	2.4	1.9	2.1	2.1	1.9		42				
44	2.4	2.6	1.8		2	2.1	1.8	1.8	2	1.9		44				
46	2.2	2.3	1.8		1.8	1.9	1.8	1.7	1.7	1.8		46				
48	1.9	2	1.8		1.6	1.7	1.8	1.5	1.6	1.6		48				
50	1.7	1.8	1.8		1.4	1.5	1.6	1.3	1.4	1.5		50				
52	1.5	1.6	1.6		1.3	1.4	1.4	1.1	1.2	1.3		52				
54	1.4	1.5	1.4		1.1	1.2	1.2			1.1		54				
56	1.2	1.3	1.3				1.1					56				
组合 Code	222211			222221			222222									

起升高度曲线图
Lifting height chart

副臂
Jib

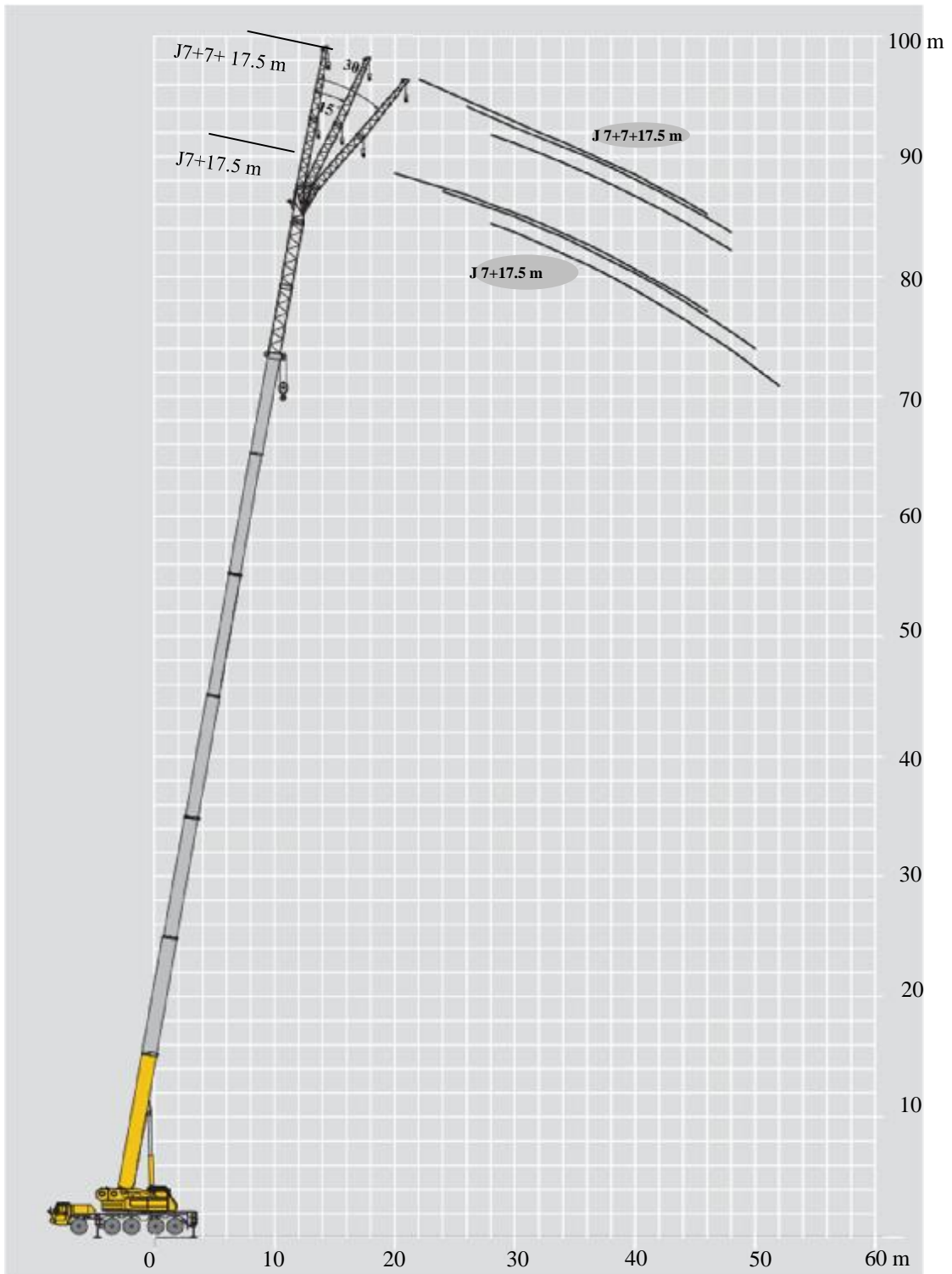

起重性能表

Lifting load tables

I 7/14 m

		58.3-67.3 m			17.5+7 m			8.32m×7.9m			360°			36 t				
		58.3+7 m			62.8+7 m			67.3+7 m										
		17.5 m			17.5 m			17.5 m										
		0°	15°	30°	0°	15°	30°	0°	15°	30°								
18	4.1				3.5							18						
20	4				3.5			2.6				20						
22	3.9	3.3			3.5	3.1		2.6				22						
24	3.8	3.2			3.4	3		2.6	2.6			24						
26	3.8	3.2	2.3		3.4	2.9	2.2	2.6	2.6			26						
28	3.7	3.1	2.3		3.3	2.9	2.1	2.6	2.6	2.1		28						
30	3.6	3	2.2		3.2	2.8	2.1	2.6	2.7	2.1		30						
32	3.5	2.9	2.1		3	2.8	2.1	2.5	2.6	2		32						
34	3.4	2.9	2.1		2.6	2.8	2	2.3	2.6	2		34						
36	3.3	2.8	2		2.3	2.7	2	2	2.6	2		36						
38	3.1	2.8	2		2	2.7	2	1.8	2.4	2		38						
40	2.8	2.8	1.9		1.7	2.4	1.9	1.6	2.2	1.9		40						
42	2.5	2.6	1.9		1.6	2.1	1.9	1.4	1.9	1.9		42						
44	2.3	2.3	1.9		1.4	1.9	1.9	1.2	1.8	1.8		44						
46	2	2.1	1.8		1.2	1.7	1.7	1.1	1.5	1.6		46						
48	1.7	1.8	1.8			1.5	1.6		1.3	1.4		48						
50	1.4	1.6	1.7			1.3	1.4		1.2	1.3		50						
52	1.3	1.4	1.5			1.1	1.2			1.1		52						
54	1.1	1.3	1.4									54						
56		1.1	1.1									56						
组合 Code	222211			222221			222222					组合 Code						

		58.3-67.3 m			17.5+14 m			8.32m×7.9m			360°			36 t				
		58.3+14 m			62.8+14 m			67.3+14 m										
		17.5 m			17.5 m			17.5 m										
		0°	15°	30°	0°	15°	30°	0°	15°	30°								
14												14						
16												16						
18	3.5											18						
20	3.5				2.5							20						
22	3.5	3.1			2.5			1.6				22						
24	3.5	3			2.5	2.5		1.6				24						
26	3.4	2.9	2.2		2.5	2.5		1.6	1.7			26						
28	3.3	2.9	2.1		2.5	2.5	2.1	1.6	1.7	1.8		28						
30	3.3	2.8	2.1		2.5	2.5	2.1	1.6	1.7	1.8		30						
32	3.2	2.8	2.1		2.5	2.5	2.1	1.6	1.7	1.8		32						
34	3.1	2.7	2.1		2.5	2.5	2.0	1.6	1.7	1.8		34						
36	3	2.7	2.1		2.5	2.5	2.0	1.6	1.7	1.8		36						
38	2.8	2.7	2		2.4	2.3	2.0	1.6	1.7	1.8		38						
40	2.5	2.6	2		2.1	2.2	2.0	1.6	1.7	1.8		40						
42	2.2	2.3	1.9		1.8	2	1.9	1.6	1.7	1.7		42						
44	1.9	2.1	1.9		1.5	1.7	1.9	1.3	1.5	1.6		44						
46	1.7	1.8	1.9		1.4	1.5	1.7	1.2	1.3	1.4		46						
48	1.4	1.6	1.7		1.1	1.2	1.5		1.1	1.2		48						
50	1.3	1.4	1.5			1.1	1.3					50						
52	1.1	1.2	1.3				1.1					52						
54			1.1									54						
组合 Code	222211			222221			222222					组合 Code						

符号标识

Description of symbols

常规标识

General symbols

	上车 Superstructure		底盘 Chassis
	起重能力 Lifting capacity		车桥 Axle
	吊臂长度 Boom length		行驶速度 Travel speed
	工作幅度 Radius		爬坡能力 Grade ability
	吊臂仰角 Boom angle		轮胎 Tires
	主臂起升高度 Hoist height with boom		支腿 Outriggers
	固定副臂长度 Fixed jib length		吊钩 Hook block
	副臂安装角 Jib offset angle		平衡重 Counterweight
	副臂起升高度 Hoist height with jib		卷扬 Winch
	独立臂头 Independent jib head		360°全回转 360° rotation
	主臂加长节 Boom extension		

主要技术参数

Table of main technical parameters

类别 Category	项目 Item	单位 Unit	参数 Parameter	
尺寸参数 Dimensions	外形尺寸 (长×宽×高) Dimensions (length× width× height)	mm	15750×3000×3900	
	轴距 Wheel base	mm	2000+3000+1420+1505	
	轮距 (前/后) Track (Front/ Rear)	mm	一、二轴(Axle 1,2) : 2488 三、四轴(Axle 3,4) : 2268 五轴(Axle 5) : 2468	
	前悬/后悬 Front/ Rear overhang	mm	2540(齐星Qixing)、2525(徐工汽车XCMG Automobile)//2753	
	前伸/后伸 Front/ Rear extension	mm	2100 (齐星Qixing) 2115 (徐工汽车 XCMG Automobile) /432	
重量参数 Weight	最大允许总质量 Max. permissible weight	kg	54600	
	轴荷 Axle load	一轴 1st axle	kg	9300
		二轴 2nd axle	kg	9300
		三轴 3rd axle	kg	13000
		四轴 4th axle	kg	13000
	五轴 5th axle	kg	10000	
动力参数 Power	发动机型号 Engine model	——	WP10.5H430E50(国五 China V)	
	额定功率/转速 Engine rated power/rpm	kW/(r/min)	316/1900	
	最大净功率/转速 Max. net power/rpm	kW/(r/min)	311/1900	
	最大输出扭矩/转速 Max. output torque/rpm	N.m/(r/min)	2000/1000-1400	
行驶参数 Travel	最高车速 Max. travel speed	km/h	≥80	
	最低稳定车速 Min. stable travel speed	km/h	1.7 ~ 3	
	最小转弯直径 Min. turning diameter	m	≤23	
	臂头最小转弯直径 Min. turning diameter at boom tip	m	≤28.8	
	最小离地间隙 Min. ground clearance	mm	270	
	接近角 Approach angle	°	18	
	离去角 Departure angle	°	11	
	制动距离 (制动初速度为30km/h) Braking distance (at 30 km/h)	m	≤10	
	最大爬坡能力 Max. grade ability	%	45	
	百公里油耗 Fuel consumption per 100 km	L	65	
噪音 Noise	加速行驶机外噪声 Exterior noise level	dB(A)	≤84	
	驾驶员耳旁噪声 Noise level at seated position	dB(A)	≤90	

主要技术参数

Table of main technical parameters

类别 Category	项目 Item		单位 Unit	参数 Parameter	
主要性能参数 Main performance	最大额定总起重量 Max. total rated lifting capacity		t	110*	
	最小额定工作幅度 Min. rated working radius		m	3.0	
	转台尾部回转半径 Turning radius at turntable tail	平衡重处 Counterweight	mm	4760	
		副卷处 Auxiliary winch	mm	4760	
	最大起重力矩 Max. load moment	基本臂 Base boom	kN.m	3840	
		最长主臂 Fully-extended boom	kN.m	1820	
		最长主臂+副臂 Fully-extended boom + Jib	kN.m	1316	
	支腿跨距 Outrigger span	纵向 Longitudinal	m	8.32 (7.8)	
		横向 Lateral	m	7.9 (6.3)	
	起升高度 Lifting height	基本臂 Base boom	m	14	
		最长主臂 Fully-extended boom	m	72	
		最长主臂+副臂 Fully-extended boom + Jib	m	97	
	起重臂长度 Boom length	基本臂 Base boom	m	13.4	
最长主臂 Fully-extended boom		m	72		
最长主臂+副臂 Fully-extended boom + Jib		m	98.8		
副臂安装角 Jib offset angle		°	0、15、30		
工作速度参数 Working speed	起重臂起臂时间 Time for raising the boom		s	65	
	起重臂全伸时间 Time for fully extending the boom		s	615	
	最大回转速度 Max. slewing speed		r/min	1.8	
	支腿收放时间 Time for extending and retracting outriggers	水平支腿 Outrigger beam	收 Retracting	s	30
			放 Extending	s	40
		垂直支腿 Outrigger jack	收 Retracting	s	40
			放 Extending	s	40
起升速度 (单绳, 第四层, 空载) Hoisting speed (single line, 4th layer, no load)	主起升机构 Main winch	m/min	130		
	副起升机构 Auxiliary winch	m/min	90		
噪声 Noise	机外辐射 Exterior noise level		dB (A)	124	
	司机位置处 Noise level at seated position		dB (A)	90	

注意事项

Notes

1. 表中额定总起重量值，是在平整的坚固地面上本起重机能够保证的最大总起重量，包括吊钩和吊具的重量，所以为了估算重物重量，必须减去上述的装置重量。
2. 表中的工作幅度为起吊重物离地时起重物到起重机回转轴线的水平距离，是包括起重臂变形量在内的实际值，因而起吊前应考虑起重臂变形量。
3. 只允许在5级(瞬时风速14.1m/s，风压125N/m²)风以下进行作业。
4. 吊重前操作者必须对物体的重量和工作范围了解后选择合适的作业工况，严禁超出表中的数值。幅度及臂长在相邻两个数值之间时，应依据两个数值中较小值确定起重作业。
5. 应按主臂仰角范围作业，即使是空载，也不应使主臂仰角处于范围外，谨防整机倾翻。
6. 表中的主臂长度应要按照每节臂的伸缩要求进行伸出。

1. The total rated load given in the rated load charts are the maximum lifting capacity when the crane is set up on firm and level ground. The total rated load includes the weight of the hook block and slings. The weight of above-mentioned devices should be deducted from the rated lifting load.
2. The working radius shown in the rated load charts is the radius when the load is lifted off the ground, and it is the actual value including loaded boom deflection. Take boom deflection into consideration before beginning a lifting operation.
3. A lifting operation is permissible only when the wind force is below grade 5 (instantaneous wind speed is 14.1 m/s, wind pressure is 125 N/m²).
4. Before beginning lifting operation, the operator should know the weight of the load to be lifted and its working range, and then select proper working conditions. Never operate the crane beyond the limit shown in the chart. Use the lower value from the chart when the boom length or working radius is between the range of values.
5. Do not extend the boom into areas of the load chart where the crane does not have capacity beyond the angles shown in the range diagrams, or tipping may occur.
6. The boom should be extended according to the telescoping code shown by digits, which means the percentage of boom sections extended.



地址：江苏省徐州市经济技术开发区高新路68号

Add : No. 68, Gaoxin Road, Economic Development Zone, Xuzhou, Jiangsu Province, China

电话(Tel) : +86-516-83462242/83462350

质量监督电话(Quality Inquiry Tel) : +86-516-87888268

备件电话(Spare Parts Tel) : +86-516-83461542

邮编(Post Code) : 221004

网址(Web) : www.xcmg.com/qizhongji

服务热线 Service Tel

400-110-9999

400-001-5678



本印刷品不属于合同。出于产品不断改进的需要，我们保留对产品型号、参数、配置进行变更的权利，恕不另行通知。图片仅供参考，具体产品以实物为准。图片中产品可能并非标准配置，部分部件可能需要另行购置。办理牌照和上路行驶需遵守当地法规。

This print does not belong to the contract. We reserve the right to modify the design (such as product model, parameters and configuration) without notice for improvement. The pictures are just for reference. The product in the picture may not be standard configuration. Some parts need to be purchased separately. Conform to the local laws for license application and road traveling.